

GMC-X1 LF

Liquid Filling Weight Indicator



GMC-X1 LF is a filling and weighing control instrument specially developed for liquid filling scales. The controller has the features of compact size, stable performance and simple operation, which is widely used in multi-head combination filling machine.



HARDWARE HIGHLIGHTS

- OIML R76 Approval;
- I/O: 5 input, 9 output;
- 2 serial ports: 1 RS485, 1 RS485 or RS232 selectable ;
- Optional: ModbusTCP or Profinet or Ethernet IP;



SOFTWARE HIGHLIGHTS

- Weight data acquisition and transmission;
- **3 filling modes:** single-head incremental, multi-head incremental, multi-head decremental;
- 20 types of recipe storage;
- Fall correction, distribution lift gun function;
- Simulation operation function;
- Printing function, print content selectable, ticket headers and trailers information editable;
- I/O port test and serial port test function.



Standard Specification

General Specifications	Model	GMC-X1LF
	Power Supply	DC 24V (12~30VDC)
	Working temperature	-10°C~40°C
	Maximum humidity	90% R.H without dew
	Testing standards	Class III 6000 e, 1 μ V/d
	Power consumption	About 5W
	A/D Conversion	A/D performance
A/D conversion speed		50~960 times/per second
Non-linearity		0.01%F.S
Gain drift		10PPM/°C
Input sensitivity		<u>0.1μV/d</u> / <u>0.5μV/d</u>
Display Accuracy		1/1,000,000
Weighing Platform Requirement		1 simulation scale interface, can connect up to 8 loadcell with 350Q, Supportsensitivity in 1mV/V, 2mV/V, 3mV/V
Sensor power supply		DC5V 200mA(Max)
Input impedance		10MΩ
Button		6 key vocalized button

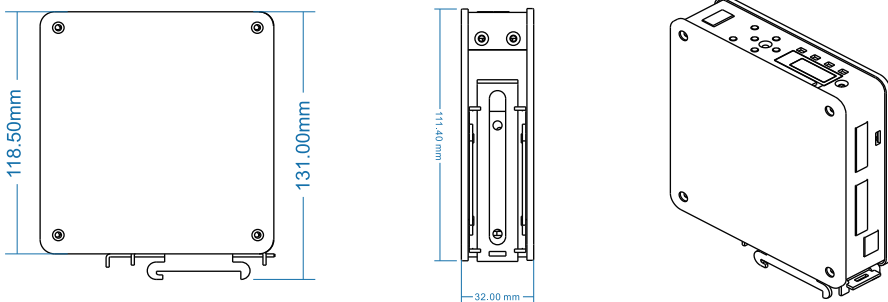

Application

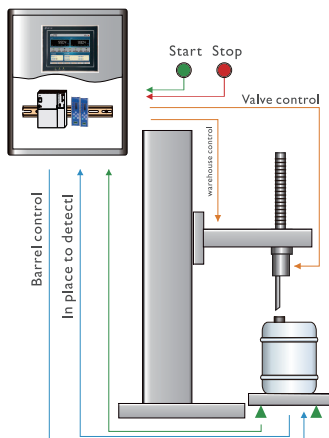

Single Nozzle for Liquid Filling Application

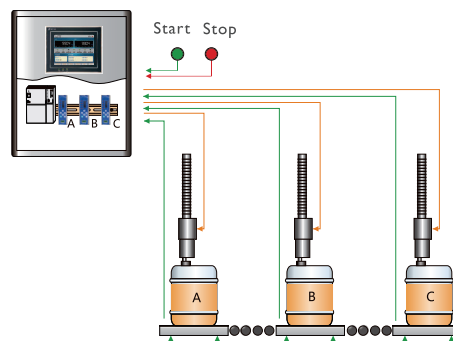

Multiple Nozzles for Liquid Filling Application